

GE Energy

3.6 MW

Offshore Series Wind Turbine

ecomaginationSM
a GE commitment



imagination at work





Arklow, Ireland
 7x 3.6s
 total capacity: 25.2 MW

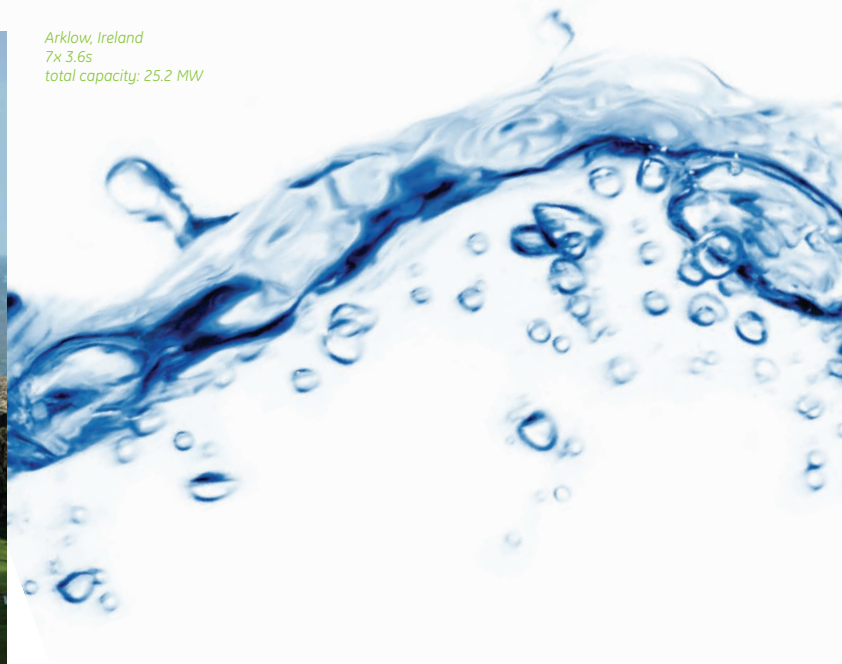

As the world’s first commercially available wind turbine expressly designed for offshore use, our 3.6 MW series machine combines the best of our proven 1.5 MW technology with valuable expertise gained from building and operating two of the world’s first multi-megawatt class off-shore wind facilities.

Engineered for high-speed wind sites and the harsh marine environment, our 3.6 MW machine features an exceptionally robust marinated design. Active yaw and pitch regulated with power/torque control capability and a double-fed asynchronous generator, it utilizes a distributed drive train design in which all nacelle components are joined on a common structure, providing exceptional durability. The generator and gearbox are supported by elastomeric elements to minimize noise emissions. The electrical container, located directly beneath the nacelle, houses the control panel, converter, switching systems and transformer. It also

provides easy access for maintenance workers and protection against corrosion. Optional cranes simplify the maintenance process, higher-efficiency blades resist dirt and abrasion, and structural improvements enhance load absorption, allowing greater reliability and longer service intervals – an important cost-savings feature, considering the rigors of offshore power generation. The 3.6 MW offshore wind turbine also employs a variety of features inherent in GE’s full line of wind turbines which range from 1.5 to 3.6 MW, for both on and offshore use. Special features include...

GE’s Fleet-Wide Features and Benefits

Feature	Benefit
Variable Hub heights & rotor diameters	Provides versatility/adaptability to a wide variety of project sites
Variable Speed Control and Advanced Blade Pitch	Enables aerodynamic efficiency and reduces loads to the drive train, thereby reducing maintenance cost and providing longer turbine life
WindVAR (optional) (Wind-Volt-Amp-Reactive “WindVAR”)	GE’s unique electronics provide transmission efficiencies and enable harmonious function within the local grid
Low Voltage Ride-Thru (optional)	Allows wind turbines to stay on line generating power, even during grid disturbances.

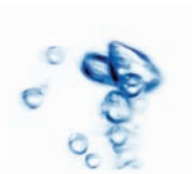

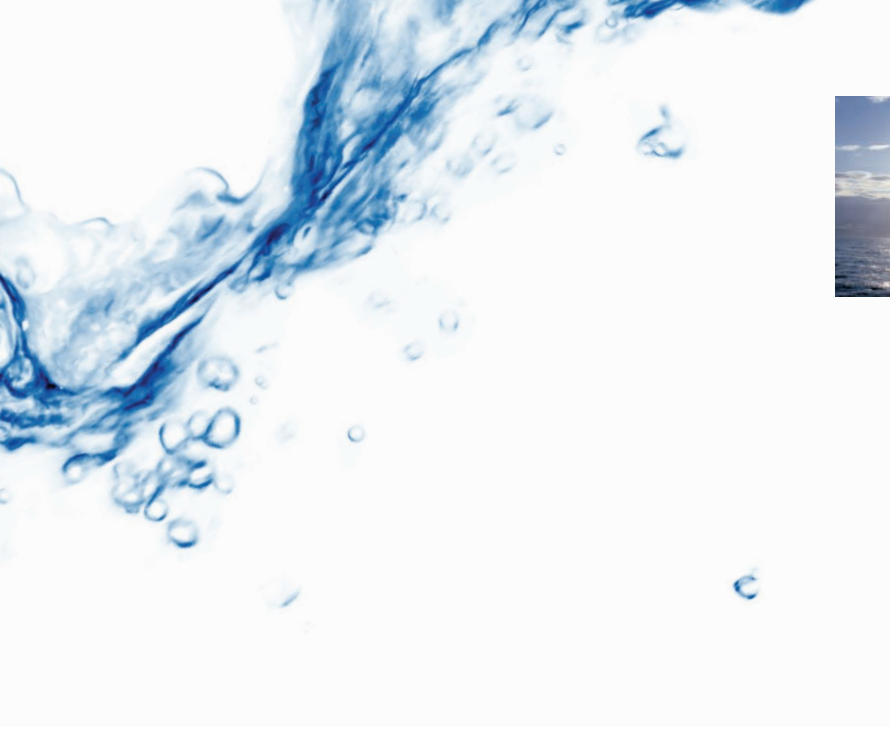

Arklow, Ireland
7x 3.6s
total capacity: 25.2 MW



In support of future offshore wind energy development, in 2003, GE built and now operates the world's first commercial offshore wind facility utilizing its 3.6 MW offshore technology. Built as a technology demonstration and learning platform for offshore wind power, GE's 25-megawatt Arklow Bank Wind Park has been operating in the harsh conditions of the Irish Sea since June 2004. To date, valuable lessons learned have been abundant and are being integrated into GE's future wind technologies, with a focus on increased cost-effectiveness, reliability and safety.

Earlier, in year 2000, the world's first "megawatt-class" offshore wind farm, Utgrunden, was completed off the south east coast of Sweden. Designed, built and operated by our team, this knowledge base has been incorporated into our 3.6 MW offshore wind turbines.

As one of the world's leading wind turbine suppliers, GE Energy's current product portfolio includes wind turbines with rated capacities ranging from 1,500 to 3,600 kilowatts and support services extending from development assistance to operation and maintenance. We currently design and produce wind turbines in Germany, Spain and the U.S.

Our facilities are registered to ISO 9001:2000. Our Quality Management System, which incorporates our rigorous Six Sigma methodologies, provides our customers with quality assurance backed by the strength of GE. We know that wind power will be an integral part of the world energy mix in this century and we are committed to helping our customers design and implement energy solutions for their unique energy needs. Every relationship we pursue bears our uncompromising commitment to quality and innovation.



Arklow, Ireland
7x 3.6s
total capacity: 25.2 MW

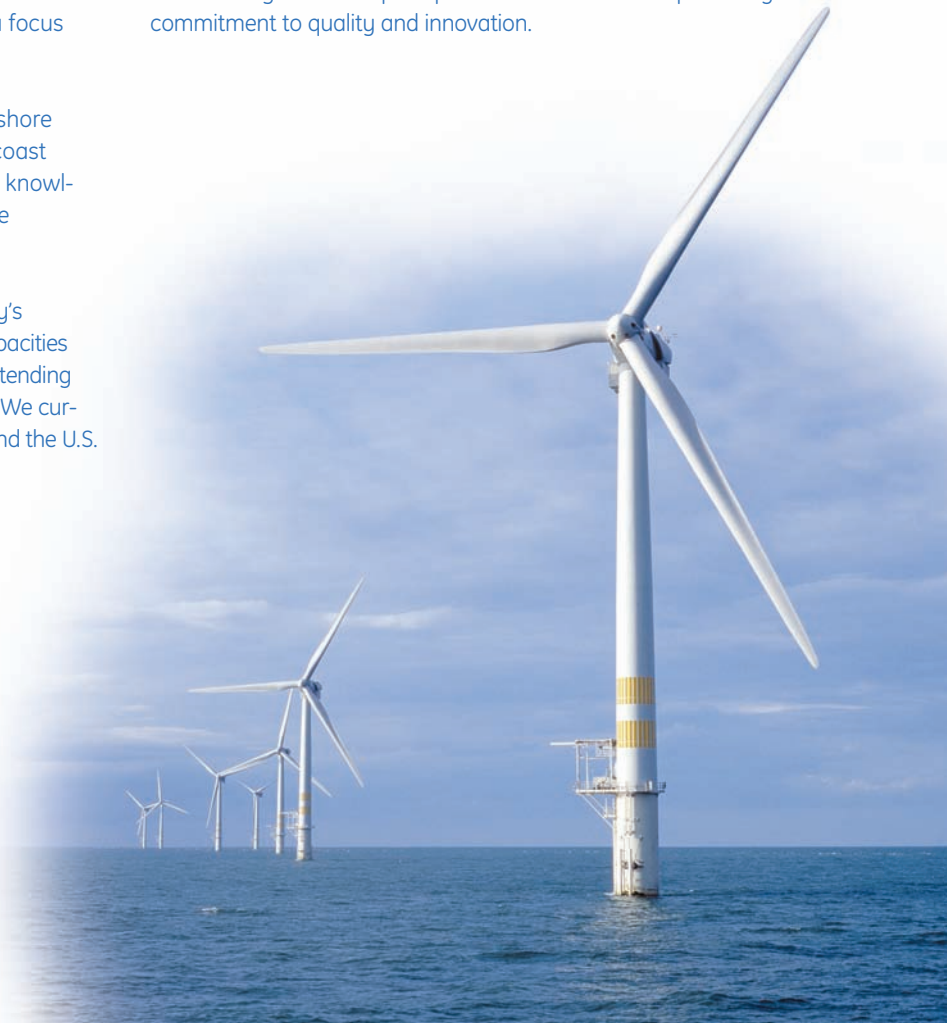

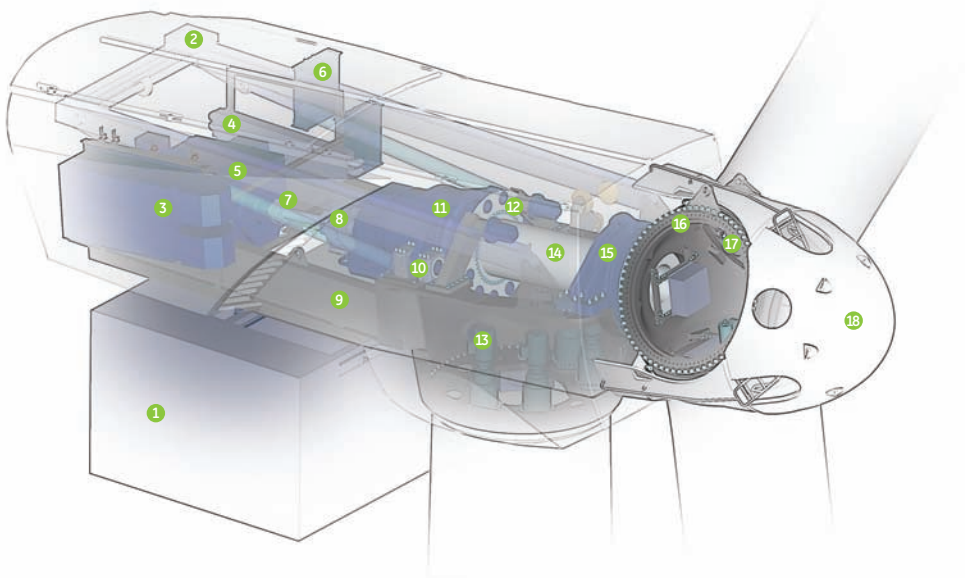

- 1 Offshore container
- 2 Small gantry crane
- 3 Generator heat exchanger
- 4 Control panel
- 5 Generator
- 6 Oil cooler
- 7 Coupling
- 8 Hydraulic parking brake
- 9 Main frame
- 10 Impact noise insulation
- 11 Gearbox
- 12 Rotor lock
- 13 Yaw drive
- 14 Rotor shaft
- 15 Bearing housing
- 16 Rotor hub
- 17 Pitch drive
- 18 Nose cone

Technical Data

3.6sl

Power Curve

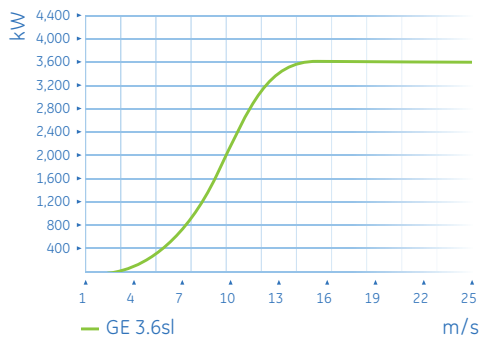

Operating data

- Rated capacity: 3,600 kW
- Cut-in wind speed: 3.5 m/s
- Cut-out wind speed: 27 m/s
- Rated wind speed: 14 m/s

Rotor

- Number of rotor blades: 3
- Rotor diameter: 111 m
- Swept area: 9677 m²
- Rotor speed (variable): 8.5 – 15.3 rpm

Tower

- Hub heights: Site dependent

Power control

Active blade pitch control

Design data

- IEC 61400-1 ed2: Type class S*

Gearbox

- Three step planetary spur gear system

Generator

- Doubly-fed asynchronous generator

Converter

- Pulse-width modulated IGBT frequency converter

Braking system (fail-safe)

- Electromechanical pitch control for each blade (3 self-contained systems)
- Hydraulic parking brake

Yaw system

- Electromechanical driven with wind direction sensor and automatic cable unwind

Control system

- PLC (Programmable logic controller) Remote control and monitoring system

Offshore container

- Protecting converter, low voltage distribution panel, transformer and control system

Lightning protection system

- Lightning receptors installed along blades
- Surge protection in electrical components
- Lightning path to ground designed to protect main bearing
- Electrical container acts as a Faraday cage, protecting the equipment against lightning strikes

Offshore tower and foundation design

- Site-specific design: monopile, transition piece, and two-section tubular steel tower
- Transition piece incorporates safe access systems and medium voltage connections

* class 1 mean & extreme, class C turbulence per 61400-1 ed.3

www.gewindenergy.com



Subject to technical alterations, errors and omissions.